

Floatation

The Aquabot is a universal pool cleaner which must perform under varying chemical and temperature conditions in your pool. The Aquabot offers the best possible performance when it is virtually weightless in your pool. Therefore careful balancing of its weight is important.

Generally, a new Aquabot is very light when used for the first time. Careful removal of air trapped in the housing is critical. Typically, additional floatation is not required on start-up.

Most pool conditions allow your Aquabot to climb the pool walls and stairs effortlessly up to the waterline. However, in some instances the pool environment (e.g., temperature, chemicals, water, etc.) may offset your cleaner's natural buoyancy. Therefore, 3 floatation devices have been included in the packaging with your new Aquabot: an "H"-Float (Ref.# 2.3) and 2 "Side Pocket" Floats (Ref.# 2.4) to assist its buoyancy.

To Add Floatation: (Figure 11)

1. Remove the 2 Screws from the "H"-Float. Then, place the "H"-Float, foam-side down, against the inside base of the Bottom Lid Assembly (Ref.# 1.20). Secure the "H"-Float with the two Screws provided by fastening them in from the outside of the Bottom Lid Assembly. This should provide adequate buoyancy.
2. Should your Aquabot require more floatation, then add the 2 remaining Pocket Floats to see if that is sufficient. Pocket Floats do not require any screws or glue. Simply place them into the open rectangular areas situated beside Intake Valves Housings (Ref.# 2.5).

Important Note:

Temperature and chemical composition changes can greatly affect the buoyancy of your Aquabot. Therefore, if you have previously installed floatation devices in your Aquabot to assist its buoyancy, it may be necessary to remove the devices one-by-one until proper buoyancy is restored.

Figure 11

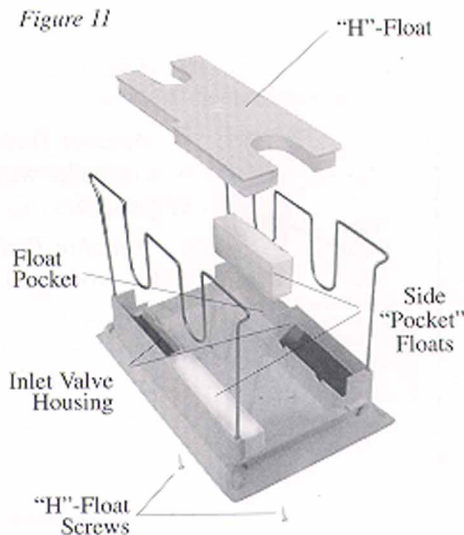
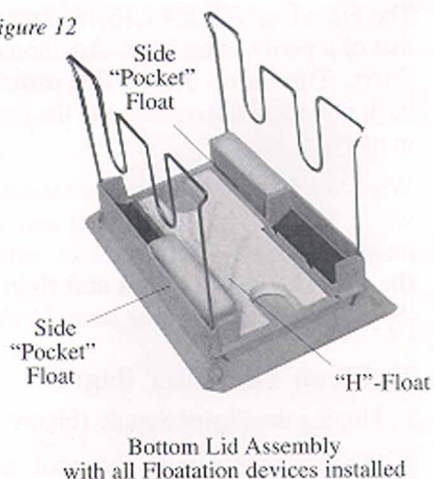

Figure 12



Propeller Care (Figures 13 A&B)

It is a good practice to inspect the Propeller (Ref.# 1.3) once or twice per season to check for obstructions which may reduce water flow and thus vacuuming ability.

First, unplug the Aquabot from the Power Supply (Figure 4). Then, use a screwdriver to remove the 4 Screws which secure the Outlet Top (Ref.# 1.2) to the Body (Figure 13A). Inspect the Propeller for clogs: hair, twigs, or other debris, which may keep it from spinning freely (Figure 13B). Remove any accumulated material and replace the Outlet Top. Be careful not to over-tighten the Screws and "strip" the Screw Holes when re-assembling.

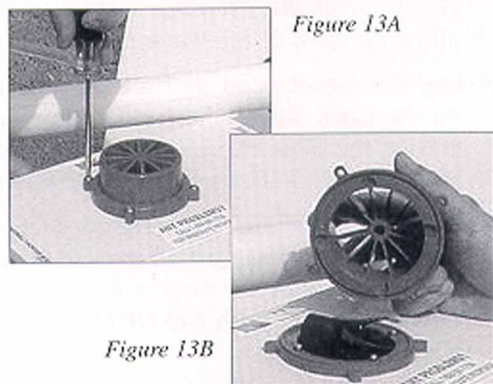

Cable Care

The Floating Cable (Ref.# 3.1) may become twisted after a period of time in use. To correct this condition, simply lock the Floating Handle (Ref.# 1.1) on the top of the Aquabot in the opposite diagonal direction (See Figures 5 & 6, Pg. 4). The Aquabot will now travel in the opposite direction along the waterline while cleaning your pool and the Floating Cable will uncoil. To manually untangle the cable using the EZ-Swivel (Ref.# 3.5) See Pg. 15. You should also check the Floating Cable periodically for external damage. Continual rubbing against sharp or rough surfaces may abrade the Floating Cable resulting in damage and possible short-circuiting of the Aquabot.

Never lift your Aquabot out of the pool using the Floating Cable. You may use the Floating Cable to pull the Aquabot to the side of the pool, but always use the Floating Handle to remove it from the pool. Pulling on the Floating Cable to remove the Aquabot from the pool will result in internal connections being broken and severe damage being caused to your Aquabot.